

Commercial Door

Description

Commercial doors provide specifiers with flexibility in design, safety and security for medium to high traffic applications. Available in hinged, pivoted or sliding options, the range can be fully integrated into the Commercial screening and Low rise curtain walling systems. Commercial doors are specifically designed for heavy-duty use in busy public places, and combine maximum resistance to wear with effective protection against vandalism.



Applications

The Commercial Door range is flexible and versatile and can be specified for a range of applications including:

- New build or refurbishment projects
- Medium to heavy traffic
- Residential and social housing
- Hotels, office blocks, schools and car showrooms
- Public & Communal entrances
- Emergency exits
- Also available with rebated frames for weather performance
- Complies with Part L of the Building Regulations
- Low threshold for compliance with Part M of the Building Regulations
- Fully integrated into the Beaufort Commercial screening and Low Rise Curtain Walling systems
- Fully compatible with the entire Beaufort Product Range
- Automatic door beam to accept all leading manufacturers automatic hardware

Design Features

- Bead glazed to accommodate 6mm-32mm single and double glazed units
- Anti-finger trap stiles for bi-swing and panic hardware
- End loaded pivot door for bi-swing operations

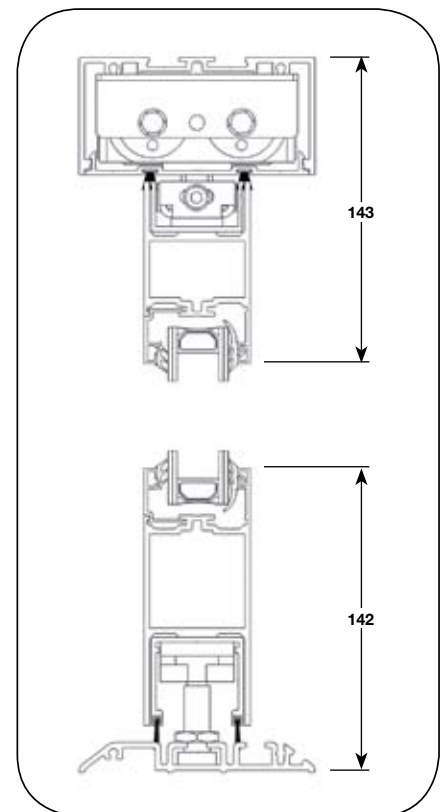

DOOR ENERGY RATING PENDING



U VALUE w/m²K PENDING



AIR PERMEABILITY PENDING



WATER TIGHTNESS PENDING



WIND RESISTANCE PENDING



BBA ASSESSMENT OF PRODUCTS FOR CONSTRUCTION PENDING



PENDING

