

Beaufort Products

Folding/Sliding Door

Description

Folding/Sliding doors help create an open, flexible and modern space for both living and working environments. Available in a range of styles and designs, panels can be stacked inside or outside of the room, to the left, right or split to stack on both sides. Door sets can be manufactured to replace entire walls to help maximise your opening space.



Applications

The Folding / Sliding Door range is flexible and versatile and can be specified for a range of applications including:

- New build or refurbishment projects
- Light to medium traffic
- Residential and social housing
- Schools and office entrances
- Pool Houses & Conservatories
- Car Showrooms

Design Features

- Internally beaded with a softline detail to all external doors and panels
- Chamfered and square bead options

- 70mm frame depth to accommodate varying types of applications
- Direct frame options for varying applications
- Various bead options to allow a glazing range of 24mm to 44mm
- Euro groove design allows for high security multi-point locking mechanisms
- Dedicated fixing straps for ease of installation
- Polyamide Thermal brake for improved thermal performance
- Complies to Part L of the Building Regulations
- Low threshold options for compliance with Part M of the Building Regulations
- Fully compatible with the entire Beaufort Product Range

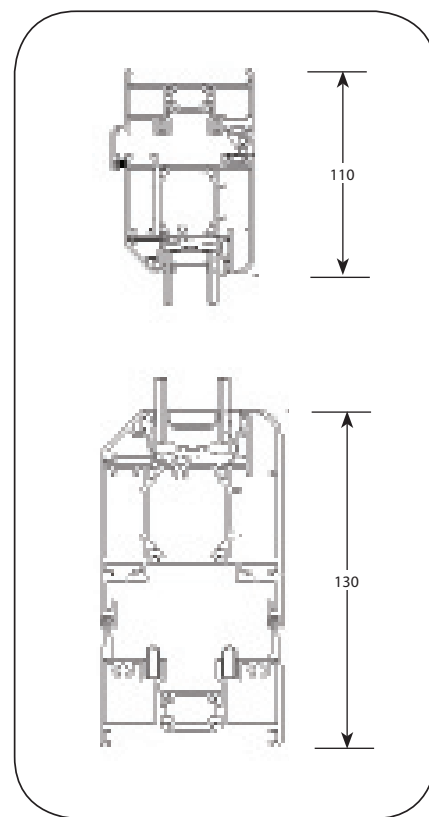

DOOR ENERGY RATING PENDING



U VALUE w/m^2K PENDING



AIR PERMEABILITY PENDING



WATER TIGHTNESS PENDING



WIND RESISTANCE PENDING



BBA ASSESSMENT OF PRODUCTS FOR CONSTRUCTION PENDING



PENDING

